



TECHNICAL SUPPORT

PLANING TOOLS

BBM produces tools according to EN847-1. We would recommend all users such as operators, service and maintenance personal, technicians etc that are in contact with the tools to thoroughly review these standards. Below is a short compilation of different tool types, appellations, techniques and basic information about working with wood and choosing the right tool.

BASIC CONCEPTS AND APPELATIONS

1. BRAZED TOOLS

The tool consists of a tool body made of untempered steel. The cutting edges are brazed to the tool body and can be ordered with different types of cutting material.

Example of tools: Cutters, drills, saw blades

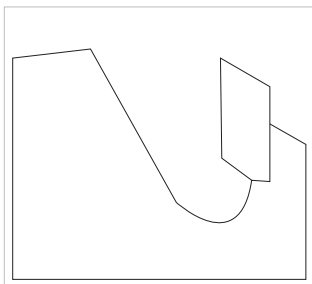

2. ASSEMBLED TOOLS

Assembled tools consist of a variety of parts mounted together. The knives are fastened by either a wedge or a directly with a screw. There are different solutions for back support, a profiled back support plate for maximum flexibility or a profiled tool body. Knives are exchangeable and available in a selection of materials.

Example of tools: Planer heads, Profile heads, indexable knife tools, BBM SpeedFlex, BBM Supreme

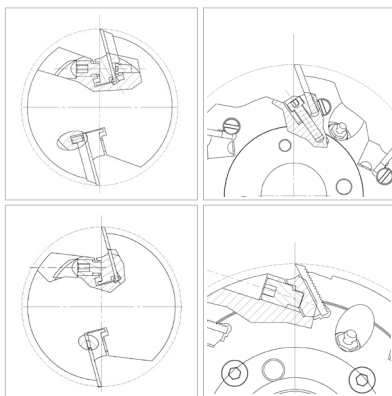

ANGLES AND GEOMETRIES

When ordering and corresponding regarding tools it is of great importance that supplier and customer use the same language and terms. Below is a short description of the technical terminology we use.

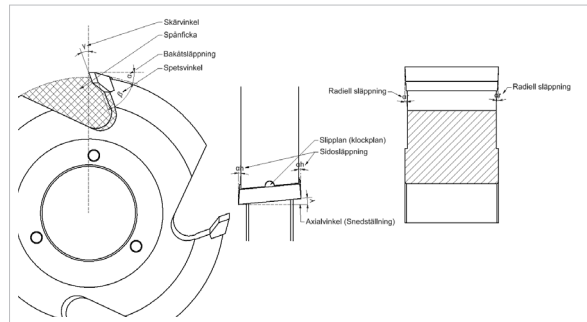

FUNDIMENTAL TERMINOLOGY, ROTATION AND PLACING

Following is terms of trade for where and how a tool is placed in your application. Normally a planer/moulder has four sides for processing. Top, bottom, right and left.

- Top = Top part of the machine
- Bottom = Bottom part of the machine
- Right = Right side looking from the in feed
- Left = Left side looking from the in feed

ROTATION

BBM always reference from the in feed side, feeding towards rotation of the tool. The vast majority of planers on the market are feeding from the right side but please advise because left side feeding does occur. See picture.

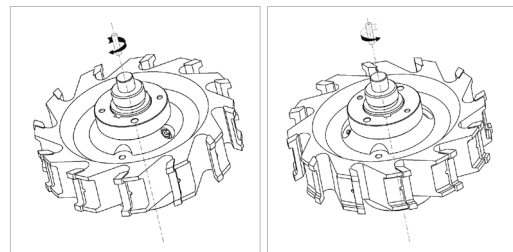

MORE INFORMATION? PLEASE CONTACT US!

Micor AB, Industrigatan 10, 312 34 Laholm, Sweden
+46 (0) 430 492 00, info@micor.se

MACHINING

1. FEEDING TOWARDS ROTATION (CONVENTIONAL MILLING)

The direction of material feed and rotation of tool is the opposite. This is the most common way for machining wood. The tool does not begin its cut directly upon contact (A) but slightly after (B). In this point the tool begins to cut a long chip that thickens until the cutting edge leaves the material (C). Feeding towards rotation allows longer running times by favorable angles and lower cutting force. Adverse fibre direction can effect cutting and result in chipping. Feeding towards rotation is the only course of action recommended for manual feed.

2. FEEDING WITH THE ROTATION (CLIMB MILLING) (HIGHLY UNCOMMON FOR PLANING/MOULDING)

The direction of material feed and tool rotation is the same. The tool immediately begins to cut upon contact and in this point starts to cut a short chip that will get thinner until the cutting edge leaves the material. Feeding like this allows good surface finish and requires lower feeding force. When feeding with rotation, running times will be effected negatively due to unfavorable angles and lack of cleavage. LSAB recommends this for mecanical feed only.

CUTTING DIRECTIONS

1. CUTTING ALONG THE FIBRES

Favorable cutting conditions which in most cases provide a good surface finish. Be advised that when cutting finger jointed materials the fibre direction can vary. Cleavage will then differ and can effect the surface finish.

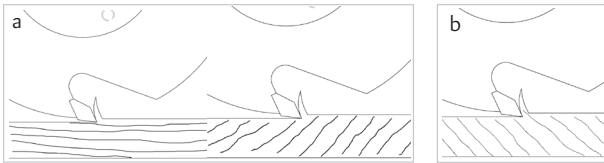

2. END GRAIN CUTTING

The angle between the tool direction and the fibres is 90°. Tough machining that can result in a slightly rough finish. Cutting can be eased by applying axial angle to the cutting edge.

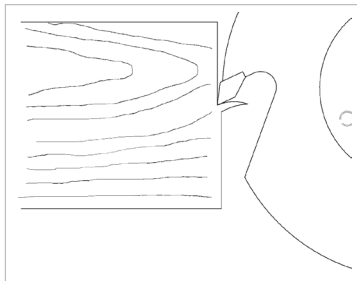

SURFACE FINISH

To maintain a high quality production it is of great importance that tools as well as machine is in good condition. By highly developed technology, competence and meticulous supervision at BBM, run out as well as profile accuracy is kept within the tightest tolerances. The surface finish when milling and sawing is determined mainly by feed per tooth, mm (mill marks), cutting diameter, amount of teeth, depth of mill marks. The ratio for these parameters is described in the following examples.

$$S_z = \frac{V_f * 1000}{N * Z} \text{ mm}$$

S_z = Feed per tooth, mill marks (mm)

V_f = Feed (m/min)

N = Revolutions per minute (rpm)

Z = Amount of teeth

Depth of mill marks can be calculated as example below

$$t = \frac{S_z^2}{4 * D}$$

t = Depth of mill marks

D = Cutting diameter

Cutting speed (periferal velocity) is decided by the tool diameter and revolutions per minute, calculated as below.

$$V_c = \frac{D * \pi * N}{1000 * 60} \text{ m}$$

D = Cutting diameter

N = Revolutions per minute

$\pi = 3,14$

When milling, shorter mill marks provide better surface finish.

$S_z = 0,3-0,8\text{mm}$ eg furniture/carpentry

$S_z = 0,8-2,5\text{mm}$ eg paneling

$S_z = 2,5-5,0\text{mm}$ eg construction wood

For tools without hydro, earlier advised formula can only be calculated with $Z=1$. To achieve a proper finish from all Z in a tool, hydro clamping is necessary.

JOINTING

When jointing a whetstone is run across the rotating tool, it is done to improve the run out. This method is mainly used on planer cutters but can also be applied for profiling. The repetition between the grinding machine and the planer can differ slightly, this will effect the run out negatively. Jointing will eliminate this deviation and provide a better surface finish. Another benefit from jointing is that it strengthens the edge of the knife, the disadvantage is that the knife loses some of its sharpness because the edge is rounded off.

MORE INFORMATION? PLEASE CONTACT US!

Micor AB, Industrigatan 10, 312 34 Laholm, Sweden

+46 (0) 430 492 00, info@micor.se

MICOR
TOOLING

SAFETY

In the process of sawing and milling wood, operators are exposed to great hazard. The tools used are heavy, very sharp and rotates at high velocity, therefore its extremely important to take part of the manuals and safety regulations provided by BBM.

BBM produces tools according to EN847-1 which is the european safety standard for milling tools and saw blades. Example of demands in EN847-1 is the grade of accuracy used for balancing the tools and also the marking of tools. Given demands for marking of for example a brazed tool is that the following parameters are permanently marked in the tool.

- The name or trade mark of the manufacturer or supplier
- The maximum rotation speed (eg max 6000rpm)
- The tool dimensions (Cutting diameter, cutting width, bore diameter)
- Cutting material group
- Integrated or manual feed (eg MEC for integrated feed)

GENERAL INSTRUCTIONS

Always follow the instructions given on a tool or drawing regarding maximum revolutions per minute. This is what the tools are designed for and exceeding it will place personnel, machine and peripherals at great risk. Most machines has an integrated solution for securing the rotation of tools and if this

solution is used the provided instructions for it applies. BBM also has a solution for securing rotation that can be applied for all types of machines. Following example show how to apply it to the spindle.

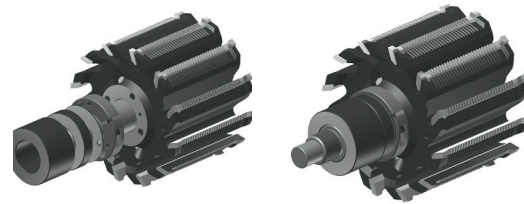

Be sure to always take part of and follow instructions and safety regulations supplied from both machine and tool manufacturers.

When cleaning tools equipped with hydro clamping be sure to always leave the pressurizing open to prevent the tool from being deformed from high temperatures in the tool washing machine. To maintain function and safety of a tool be sure to always use original BBM spare parts for all types of service and repair. Below is a selection of the most common spare parts from BBM.

TOOL TYPE	SPARE PART	ARTICLE	AREA OF USE
BBM Helix	Screw for insert knives	Helixskruv R20	Fastening insert knives
BBM Helix	Standard Helix insert knife	15152,5-R115C	Insert knife
BBM Cutter heads, Profile heads	Screw M12	32087	Fastening wedges and knives
BBM Supreme	Screw M5	TOR1924	Screw for side fixation
BBM Supreme	Screw M6x20	95217-0	Fastening wedges and knives
BBM Supreme	Screw M6x25	95218-0	Fastening wedges and knives
Hydro tools	Pressurizing nipple	32088	Pressurizing hydro tools
Hydro tools	Release nipple	32089	Releasing pressure
Hydro tools	LSAB Hydro grease cartridge	K33090	Grease for hydro tools
Miscellaneous	Adjustable torque wrench 5-14Nm	V745500	Safe fastening of knives
Miscellaneous	Bit holder for torque wrench	V745540	Safe fastening of knives

Tools produced for integrated feed must NEVER be used for manual feed.

MORE INFORMATION? PLEASE CONTACT US!

Micor AB, Industrigatan 10, 312 34 Laholm, Sweden
+46 (0) 430 492 00, info@micor.se

THE IMPORTANCE OF TORQUE

For tools where the cutting edge is fixed with screws or friction it is very important to follow the instructions about torque provided. Torque is calculated to keep the cutting edge in the right place. Not applying the correct torque can cause the cutting edge to move out of position or leave the tool body. To ensure that you apply the correct torque use a torque wrench. The accuracy of the torque wrench should be controlled frequently. BBM recommends every 6 months.

Following is a table of which torque to be used for BBM tools. Always follow instructions and safety regulations provided by machine and tool manufacturers to keep free from incidents and uphold a safe and productive work place. Always use the packaging supplied from BBM for service and if possible storage. If a tool has or is suspected to have been exposed to undue influence, shows signs of or has visible damages always contact BBM for consulting before continued use.

TOOL TYPE	SCREW	TORQUE
BBM Helix	HelixskruvR20 M6	7Nm
BBM Cutter head, flat knives	32087 M12	45Nm
BBM Cutter head Light	32087 M12	18Nm
BBM Cutter head, serrated knives	32087 M12	18Nm
BBM Profil cutter head	32087 M12	18Nm
BBM Supreme	95217(18)-0 M6	12Nm
Hydro tools	Pressure nipples 32088, 32089	14Nm
Cutter heads flat knives, external supplier	M10	32Nm
Cutter heads flat knives, external supplier	M12	45Nm

MORE INFORMATION? PLEASE CONTACT US!

Micor AB, Industrigatan 10, 312 34 Laholm, Sweden
+46 (0) 430 492 00, info@micor.se

MATERIAL SPECIFICATION



HSS

BBM's High Speed Steel is optimized for heat resistancy and excellent running times. It is suitable for soft materials and stays sharp over time.

Hardyx

BBM developed cutting material, made by Micor Toling in Sweden. Hardyx enables substantially longer running times compared to HSS, allows a higher feeding speed through the planer and provides a higher finish on the processed material. Hardyx is suitable for requiring applications with high demands on liability.

Hardyx is specially suitable for machining materials with hard knots. Its high resistancy to cracks keeps it more stable when cutting through the strains that occur in the transition between soft and hard materials. This also applies for foreign objects that may enter the planer such as rocks, clips etc. We often recommend Hardyx when working with tool optimizing projects.

HW













BBM has a special grade tungsten carbide called OptiPine. Its a tough and less brittle grade which makes it more resistant to cracks and damage when

working materials with hard knots. Its characteristics provides a very high resistancy and very long running times.

PCD

PCD (Polycrystalline diamond) In applications that demands extremely hard cutting materials we can use PCD. Its characteristics makes it very resistant for wear and provides a long tool life time. PCD is fused under high pressure and very high temperature. Please contact your BBM sales person for more info.

SYMBOLS











 HSS	 GalaxPro	 Soft wood	 Hydro bushing	 Anti vibration
 Hardyx	 Galaxpro+	 Hard wood	 Hydro sleeve	 Integrated feeding
 Carbide	 ProLite	 Hydraulic fastening	 Solid hydro	 Assembled tools
				 Brazed tools

MORE INFORMATION? PLEASE CONTACT US!

Micor AB, Industrigatan 10, 312 34 Laholm, Sweden
+46 (0) 430 492 00, info@micor.se

LET US HELP YOU CHOOSE

In the table below we have made it easy for you to find the right type of cutting material for your needs.

			
HSS			
HX			
HW			
GXP			
GXP+			

The above is general recommendations.
Always contact us before starting production.

MORE INFORMATION? PLEASE CONTACT US!

Micor AB, Industrigatan 10, 312 34 Laholm, Sweden
+46 (0) 430 492 00, info@micor.se